



# VT-450/650

Vertical Turning Center  
12" - 24" Chuck with Quick Turret Type





# VERTICAL TURNING CENTER 12"-24" CHUCKER QUICK TURRET TYPE

## 12"-24" vertical turning center for mass production

VT-450/650 turning centers reducing cutting time, the rigid high-speed tool turret is durable with high speed indexing, providing consistent and stable machining performance most suitable for mass production.

1 Brake Hub / Automobile / GC300 2 Pressure Plate / Automobile / GC250 3 Valve Body / Plant Industry / SCW410

4 Brake Drum / Automobile / GC250 5 Brake Disk / Automobile / GC200

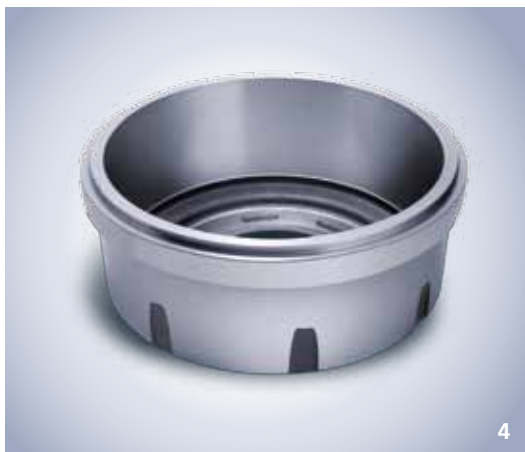

# HEAVY DUTY MACHINING STABILITY

VT-450/650 turning centers have been the preferred choice for many Manufacturers around the world. They have demonstrated exceptional capabilities by machining brake discs, brake drums, hubs and valves. The one piece machine bed design limits thermal distortion and absorbs vibration effectively and it guarantees high surface quality and precision at high speed. These turning centers can be ordered with the spindle on the left or the right side, or as double machine where the operator can work on two machines with one control. The fast and effective chip disposal and the environment friendly oil-water separation design will make your production more efficient and cost effective.





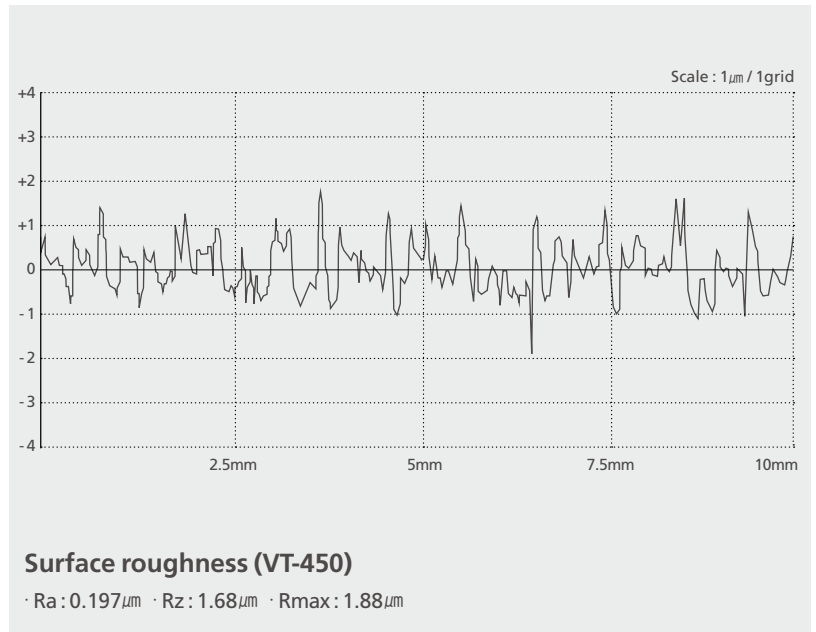
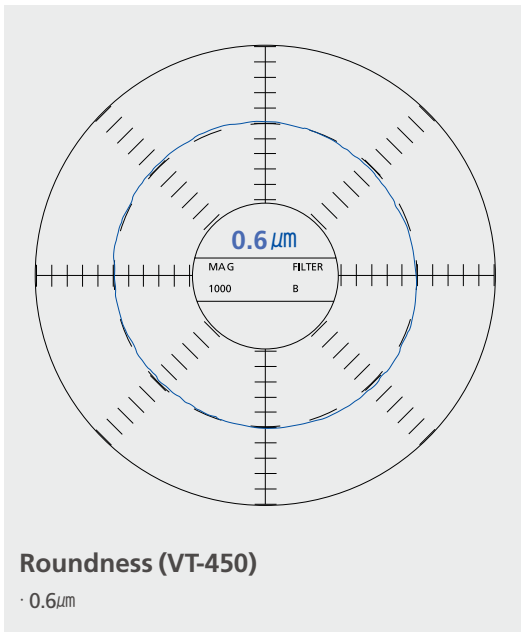

- Tool : DNMG150608 · Material : Brass · External diameter : 100mm
- Cutting depth : 0.1mm · Spindle RPM : 1,000rpm · Feedrate : 0.06mm/rev

### Highly rigid and durable one piece frame structure

The VT-450/650 turning centers have a one piece bed frame for excellent vibration absorption, it guarantees high precision and surface quality at high speed turning thanks to the frame's ability to limit thermal distortion. The Z-axis guide is built in box way design, the X-axis is designed with linear Roller Guides for precision and rigidity to keep machine fast, sturdy and stable during long hours of operation.



### Interference free operation

The max. turning diameter zone is designed to provide interference free operations. Providing same max. diameter at full length even on larger workpieces.

\* Unit: mm(inch)

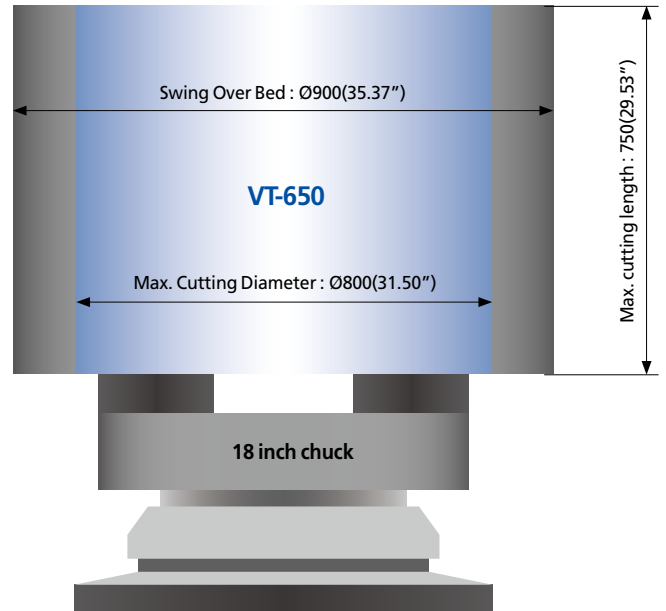
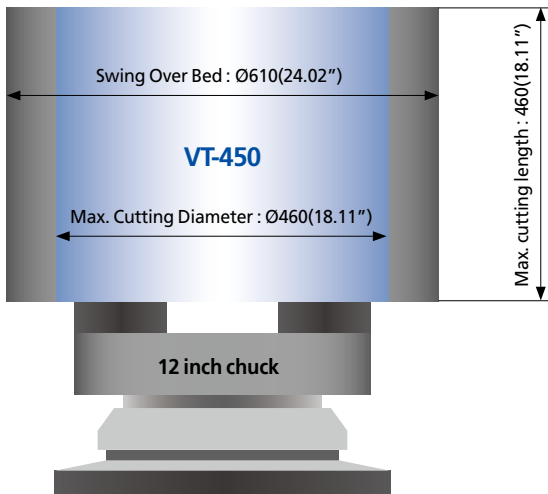

### Environment-friendly design

To prevent the lubrication oil from dripping on the workpiece surface during dry cutting, the cutting area and moving machine parts are completely separated. The environment-friendly machine design drains the lubricant oil separately and is eliminating the need for a separator unit.

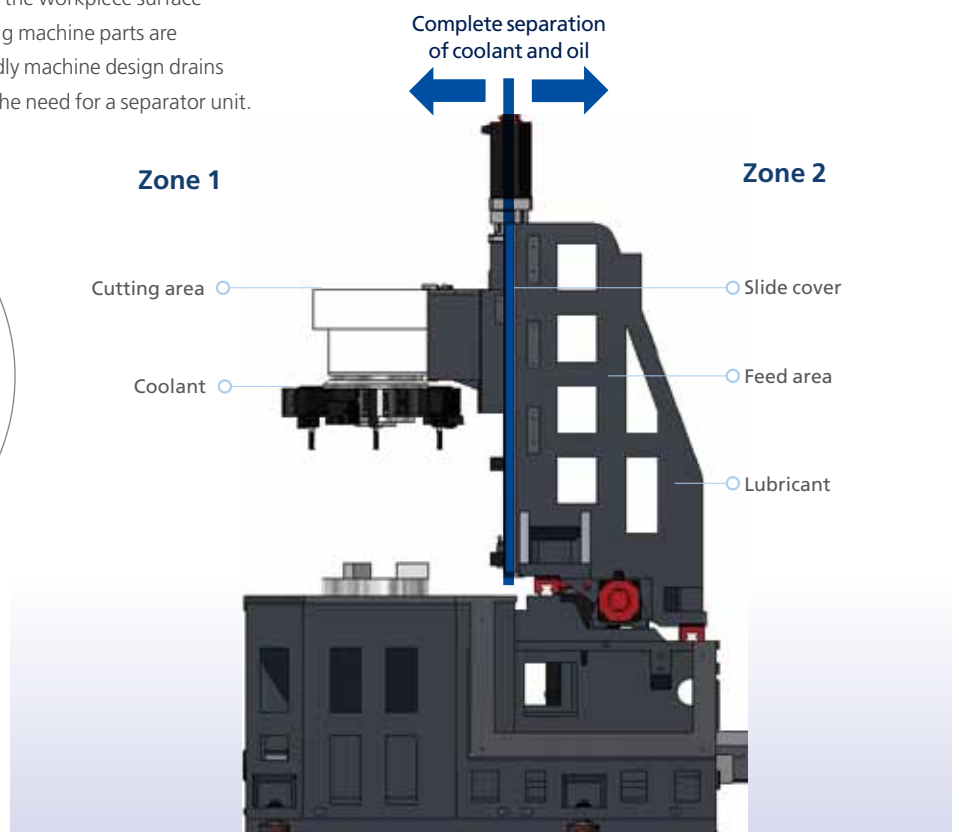
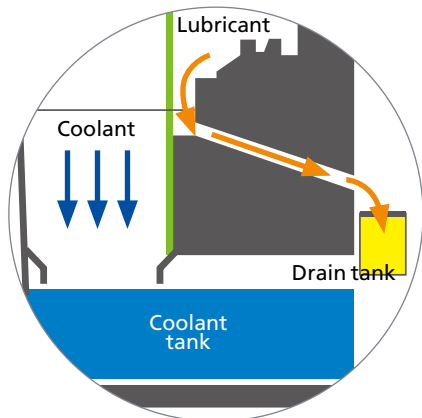



# USER FRIENDLY DESIGN, A WIDE RANGE OF OPTIONAL FEATURES

VT-450/650 turning centers are designed with the end user in mind. The user-friendly machine design and a variety of supplementary options made for stronger, faster, and more precise machining performance.



Changing tools is convenient when the ATC returns to its parking position, according to the side access door (VT-650)



## L-HTLD: Hwacheon Lathe Tool Load Detect System (Option)



The Hwacheon Lathe Tool Load Detect System constantly detects and diagnoses the tool load under process to prevent tool wear and damage, and to keep your machine and tools in optimal shape.

### Load Detection Limit 1

#### Alarm + Feed Hold

> When the LIMIT 1 Alarm sounds, the system holds the feed and the machine goes into standby.

### Load Detection Limit 2

#### Alarm + Machine Stop

> When the LIMIT 2 Alarm sounds, the system stops the machine, and must be reset to operate it.

## High torque gear box(Option)

Power is delivered to the spindle through a two speed transmission allowing high spindle speed as well as powerful low torque



Product Data

\* Unit: mm(inch)

VT-450/2SP

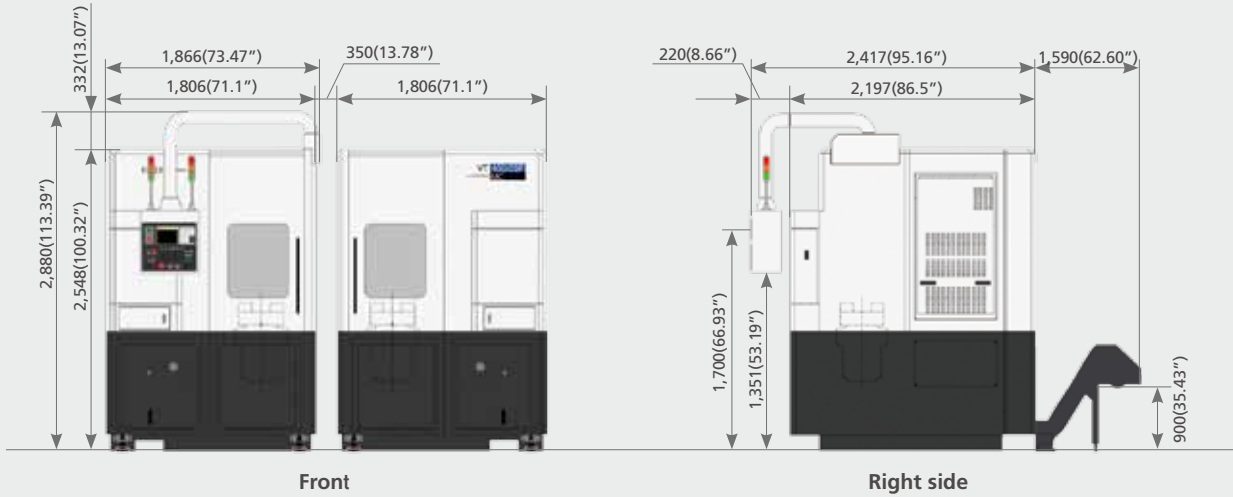

VT-650/2SP

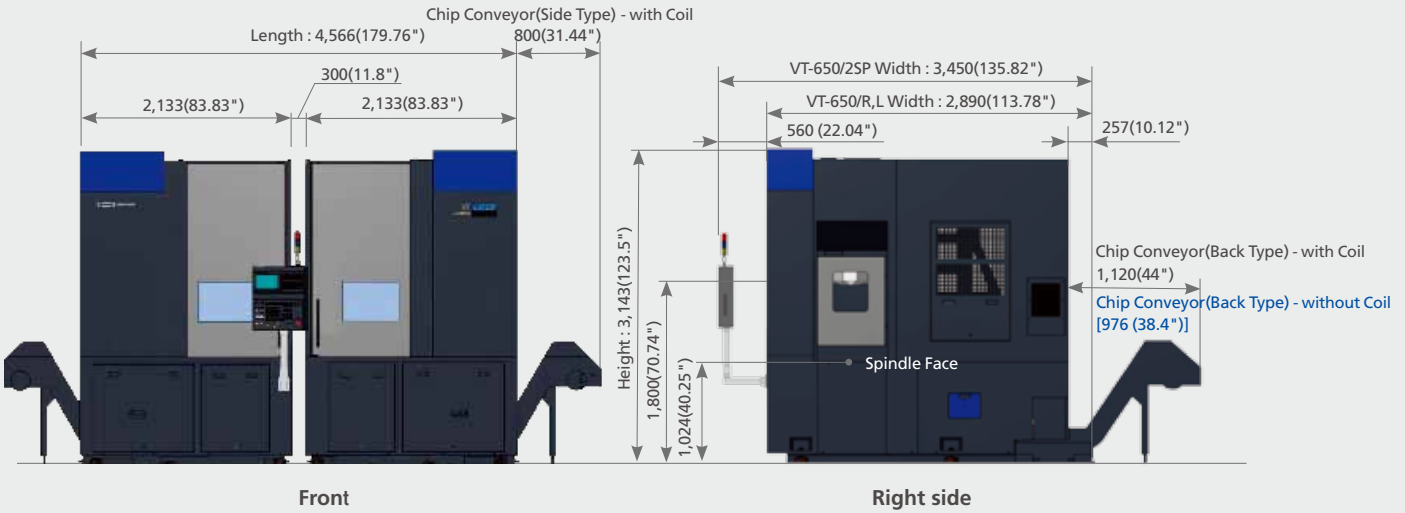

Spindle Power-Torque Diagram

VT-450(STD)

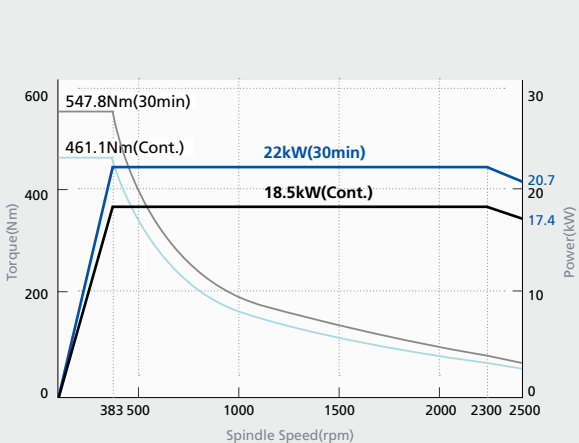

VT-650(STD)

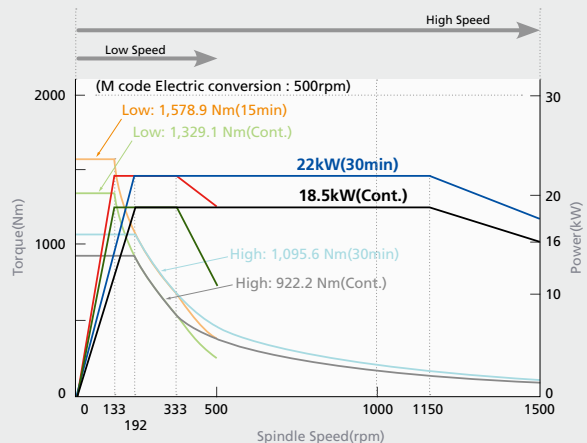

Tool Interference Diagram

※Unit : mm(inch)

VT-450 STD(8 station)

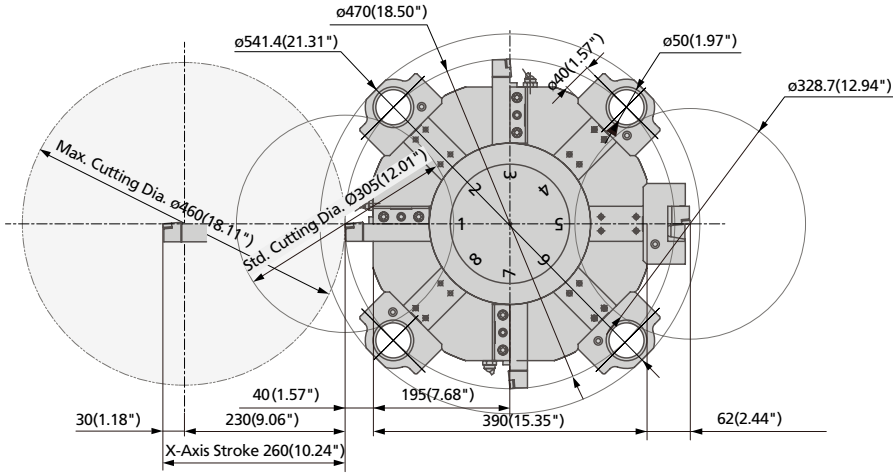

VT-450 MC (10 station)

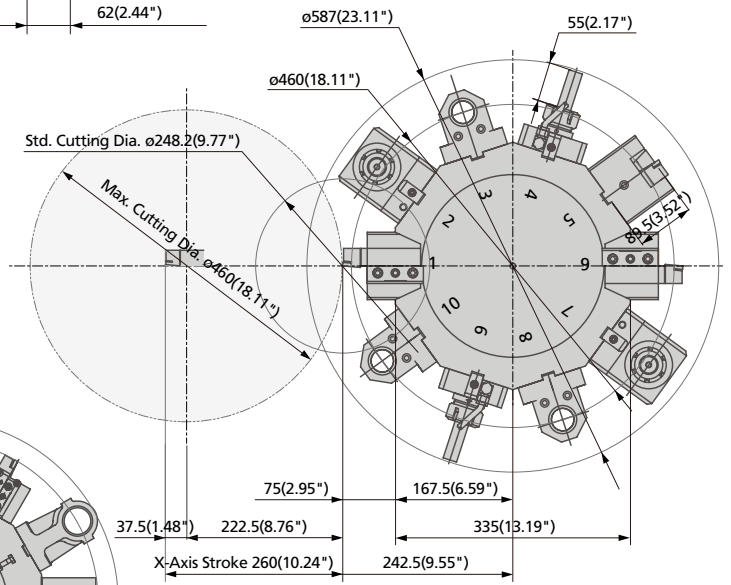

VT-650 STD

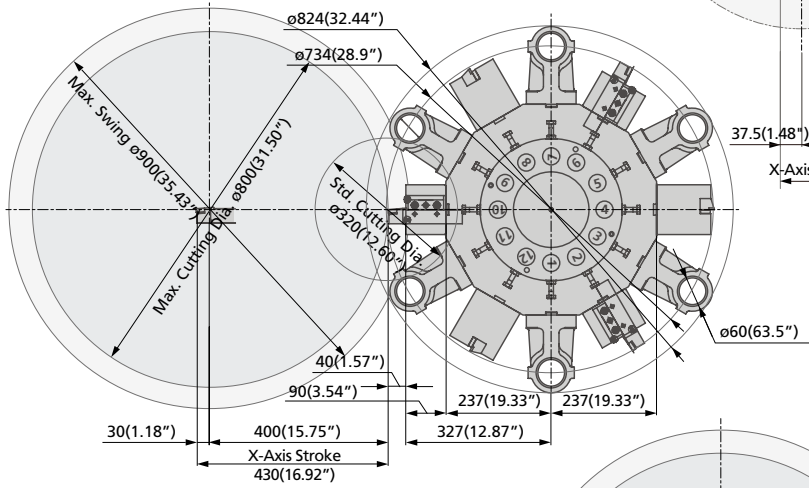

VT-650 MC

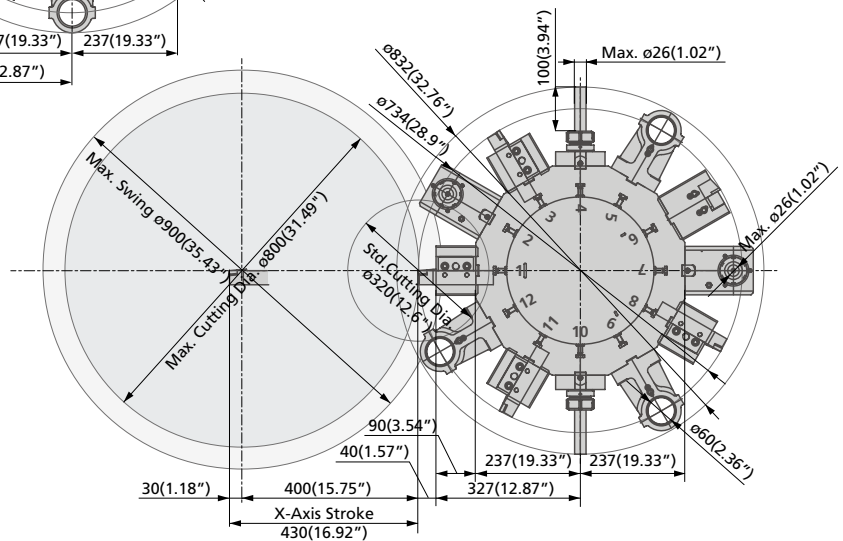

Moving Range

※Unit : mm(inch)

VT-450

STD

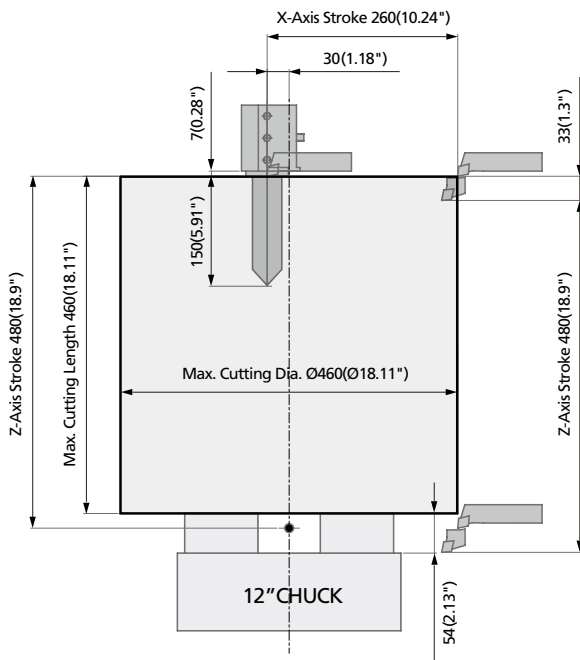

MC

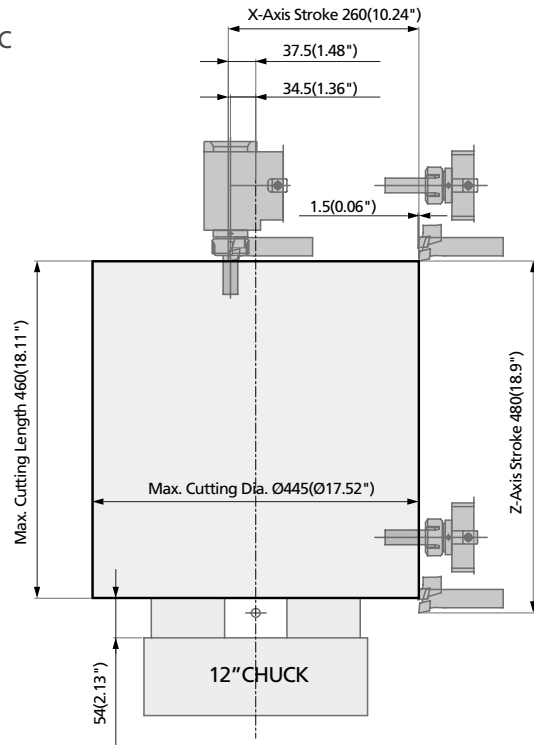

VT-650

STD

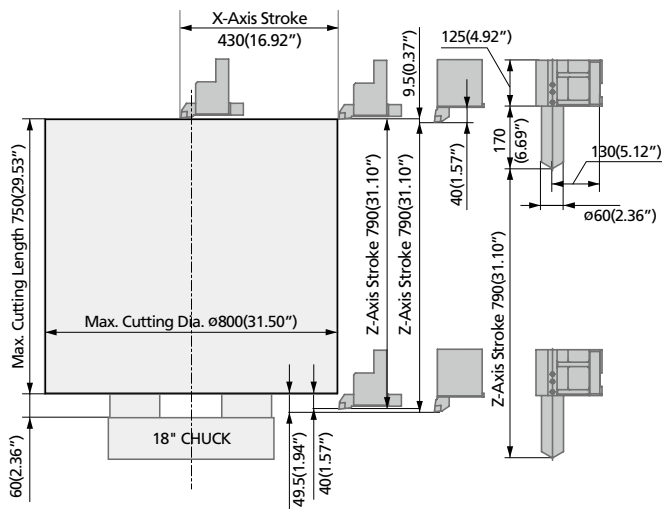

MC

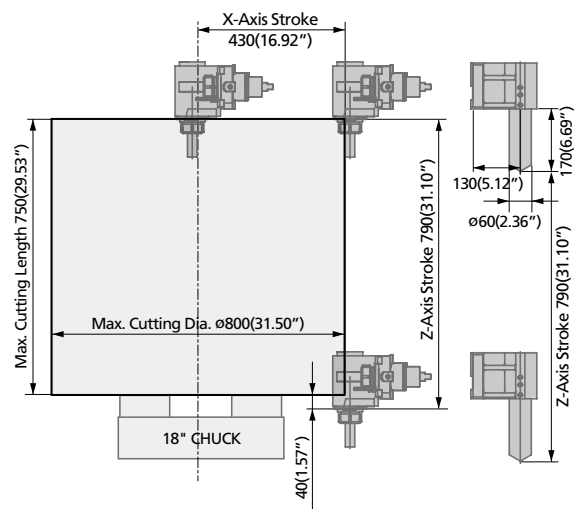

## Product Configuration

Each product can be configured to fit your application.

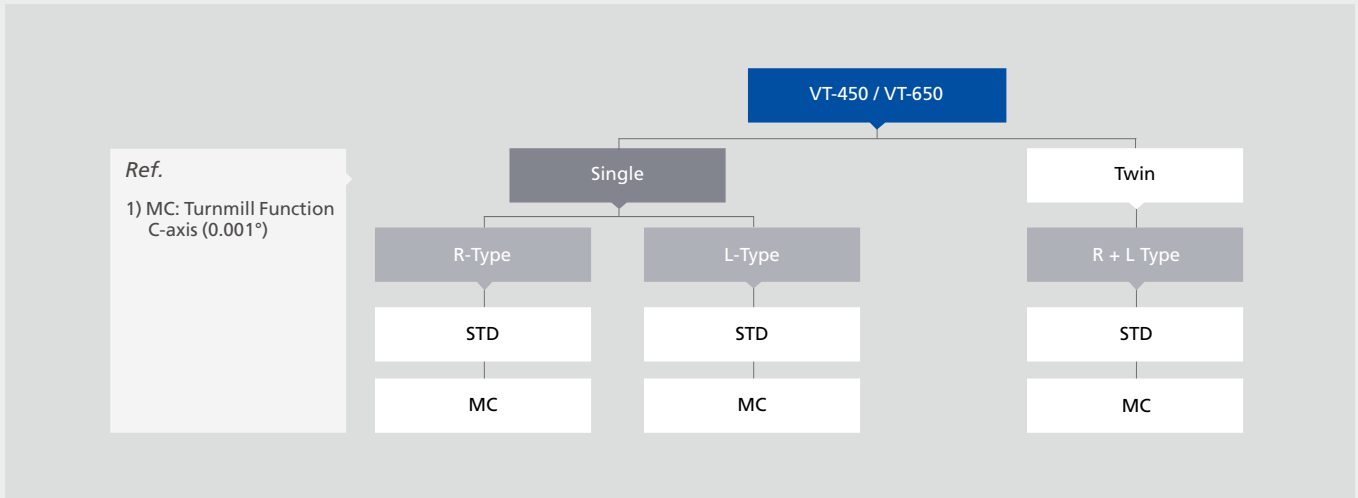

## Machine Specifications

ITEM		VT-450 (R, L)	VT-450MC	VT-650 (R, L)	VT-650MC
<b>Capacity</b>					
Swing over bed	mm(inch)	Ø610 (24.02")		Ø900 (35.37")	
Max. Cutting diameter	mm(inch)	Ø460 (18.11")		Ø800(31.44")	
Standard Cutting diameter	mm(inch)	Ø305 (12.01")	Ø248.2(9.77")	Ø320(12.57")	
Max. Cutting length	mm(inch)	460 (18.11")		750(29.53")	
Chuck Size	inch	12"		18"	
<b>Spindle</b>					
Type of spindle nose	ASA	A2-8		A2-11	
Max. Spindle speed	rpm	2,500		1,500	
Spindle bearing inner diameter	mm(inch)	Ø130 (5.12")		Ø160 (6.30")	
Spindle motor	kW(HP)	22/18.5 (30/25)		22/18.5 (30/25)	
<b>Turret</b>					
Number of tool station	ea	8	10	12	
Tool size	mm(inch)	□25 x Ø50 (□1" x Ø2")		□32 x Ø60 (□1.25" x Ø2.5")	
Turret indexing time	sec/step	0.15		0.2	
<b>Feedrates</b>					
Rapid speed (X/Z)	m/min(ipm)	24/20(944.88/787.4)		20/16(787.4/629.9)	
Max. Stroke (X/Z)	mm(inch)	260/480 (10.24"/18.9")		430/790 (16.89"/31.04")	
Feed Motor (X/Z)	kW(HP)	4.0/4.0(5.5/5.5)		3.0/4.0(4/5.5)	
<b>Turnmill (Opt.)</b>					
Spindle motor	kW(HP)	-	3.7/2.2 (5/3)	-	5.5/3.7(5/3)
Max. Spindle speed	rpm	-	3,000	-	3,000
Max. Drill/Tap size	mm	-	Ø16(0.63") / M12	-	Ø26(1") / M20
Min. Index angle	°(deg)	-	0.001°	-	0.001°
<b>Tank Capacity</b>					
Lubrication	ℓ (gal)	12 (3.17)		12 (3.17)	
Hydraulic	ℓ (gal)	11 (3)		50 (13)	
Coolant	ℓ (gal)	150(40)		195 (52)	
<b>Power Sources</b>					
Electrical power supply	kVA	40		40	
<b>Dimension</b>					
Height	mm(inch)	2,548 (100.32")		3,220 (126.55")	
Floor space (LxW)	mm(inch)	1,806 x 2,197(71.1" x 86.5")		2,130 x 2,840(83.1" x 111.6")	
Weight	kg(lb)	7,500 (16,535)	7,550 (16,645)	10,450 (23,038)	10,550 (23,259)
<b>NC Controller</b>		Fanuc 0i-TD			



### Standard and Optional Product Components

■ VT-450/650 ■ VT-450 ■ VT-650

Standard Accessories		Optional Accessories	
• Coolant system	• Turret 8 station	• Air blower	• Manual guide i
• Door interlock	• Turret 12 station	• Air curtain (Head, ATC)	• Mist collector
• Foot switch	• U-Drill holder 1ea	• Air gun	• NC cooler
• High pressure pump 6bar	• Work light	• Auto door	• Signal lamp with 3 color (R,G,Y)
• Hydraulic unit 40kg/cm <sup>2</sup>	• 10.4" LCD monitor	• Chip Conveyor & Chip box(Back type)	• Spindle motor upgrade (α30)37/30kW
• Leveling bolt & plate	• 12" Hydraulic chuck & cylinder	• Chip conveyor & Chip box (Side type) - with coil	• Spindle motor upgrade (α40)45/37kW
• Lubrication unit	• 18" Hydraulic chuck & cylinder	• Chip conveyor & Chip box (Back type) - with coil	• Tool & work counter, External / Internal
• Manual & parts list		• Chuck dual pressure system	• Tool life management
• Set of soft jaws		• Chuck pressure check swith	• Tool presetter(Automatic)
• Signal lamp with 2 colors(R,G)		• Chuck pressure compensation	• Tool presetter(Manual)
• Tool kit & box		• Coolant gun	• Transformer
• Tooling System		• Hard jaw	• Turmill funtion including C-axis(0.001")
		• High pressure coolant system, 6bar /15bar	• Turmill holder, Axial / Radial
		• High pressure coolant system 15bar	• Z.F Gear box
		• L-HTLD(Lathe-Hwacheon Tool Load Detect)	• Z.F Gear box (α40 only)
		• Linear scale(X/Z)	• 15" Chuck & Cylinder (Spindle A2-11)
			• 15",21",24" Chuck & cylinder

### NC Specifications [Fanuc Oi-TD]

※ - : Not available S : Standard O : Option

ITEM	SPECIFICATION	STD	MC	ITEM	SPECIFICATION	STD	MC
<b>Controlled axis</b>				<b>Program input</b>			
Controlled axis (Cs axis)	2-Axes	2-Axes	3-Axes	Programmable data input	G10	S	S
Simultaneously controlled axes	2-Axes	2-Axes	3-Axes	Sub program call	10 folds nested	S	S
Least input increment	0.001mm, 0.001deg, 0.0001inch	S	S	Custom macro B		S	S
Least input increment 1/10	0.0001mm, 0.0001deg,0.00001inch	O	O	Addition of custom macro -common variables	#100-#199, #500-#999	S	S
inch/metric conversion	G20, G21	S	S	Canned cycles		S	S
Stored stroke check 1		S	S	Multiple repetitive cycle		S	S
Stored stroke check 2,3		S	S	Multiple repetitive cycle II		S	S
Chamfering on/off		S	S	Canned cycles for drilling		S	S
Backlash compensation		S	S	Small-hole peck drilling cycle		S	S
<b>Operation</b>				Manual guide i		O	O
Automatic & MDI operation		S	S	<b>Spindle speed function</b>			
Program number search		S	S	Constant surface speed control	G96 / G97	S	S
Sequence number search		S	S	Spindle override	50 - 120%	S	S
Dry run, single block		S	S	Spindle orientation		S	S
Manual handle feed	1Unit	S	S	Rigid tapping		O	S
Manual handle feed rate	x1, x10, x100	S	S	Spindle synchronous control		-	-
<b>Interpolation function</b>				<b>Tool function / compensation</b>			
Positioning	G00	S	S	Tool function	T4-digits	S	S
Linear interpolation	G01	S	S	Tool offset pairs	64pairs	S	S
Circular interpolation	G02, G03	S	S	Tool nose radius compensation		S	S
Dwell (Per seconds)	G04	S	S	Tool geometry/wear compensation		S	S
Polar coordinate interpolation	G12.1 / G13.1	-	S	Tool life management		O	O
Cylindrical interpolation	G7.1	-	S	Automatic tool offset	Tool presetter option is required	O	O
Threading	G32	S	S	Direct input tool offset value measured B	Tool presetter option is required	O	O
Multiple threading		S	S	<b>Editing operation</b>			
Threading retract		S	S	Part program storage length	1,280m(512kB)	S	S
Continuous threading		S	S	Number of register able programs	400ea	S	S
Variable lead threading	G34	S	S	Background editing		S	S
Reference position return 1st	G28	S	S	Extended part program editing		S	S
Reference position return check	G27	S	S	Play back		S	S
2,3,4th reference position return	G30	S	S	<b>Operation/Display</b>			
<b>Feed function</b>				Clock function		S	S
Rapid traverse override	F0, F25, F50, F100	S	S	Self-diagnosis function		S	S
Feed per minute (mm/min)	G98	S	S	Alarm history display		S	S
Feed per revolution (mm/rev)	G99	S	S	Help function		S	S
Rapid traverse bell-shaped acceleration/deceleration		S	S	Run hour and parts count display		S	S
Feedrate override	0 - 150 %	S	S	Graphic function		S	S
Jog feed override	0 - 1,260 mm/min	S	S	<b>Multi-language display</b>			
<b>Program input</b>				Multi-language display	English, German, French, Italian, Chinese, Spanish, Korean, Portuguese, Polish, Hungarian, Swedish,Russia	S	S
Tape code	EIA RS244 / ISO840	S	S	<b>Data input/output</b>			
Optional block skip	1ea	S	S	Reader/Puncher interface CH1	RS232C	S	S
Program number	O4 - Digits	S	S	Reader/Puncher interface CH2	RS232C	S	S
Sequence number	N5 - Digits	S	S	Ethernet interface	Embedded Ethernet	S	S
Decimal point programming		S	S	Memory card interface		S	S
Coordinate system setting	G50	S	S	<b>Others</b>			
Coordinate system shift		S	S	Display unit	10.4" color LCD	S	S
Workpiece coordinate system	G54 - G59	S	S				
Workpiece coordinate system preset	G92.1	S	S				
Direct drawing dimension programming		S	S				
G code system	A	S	S				

## Hwacheon Global Network

 Hwacheon Headquarter  Hwacheon America  Hwacheon Europe  Hwacheon Asia

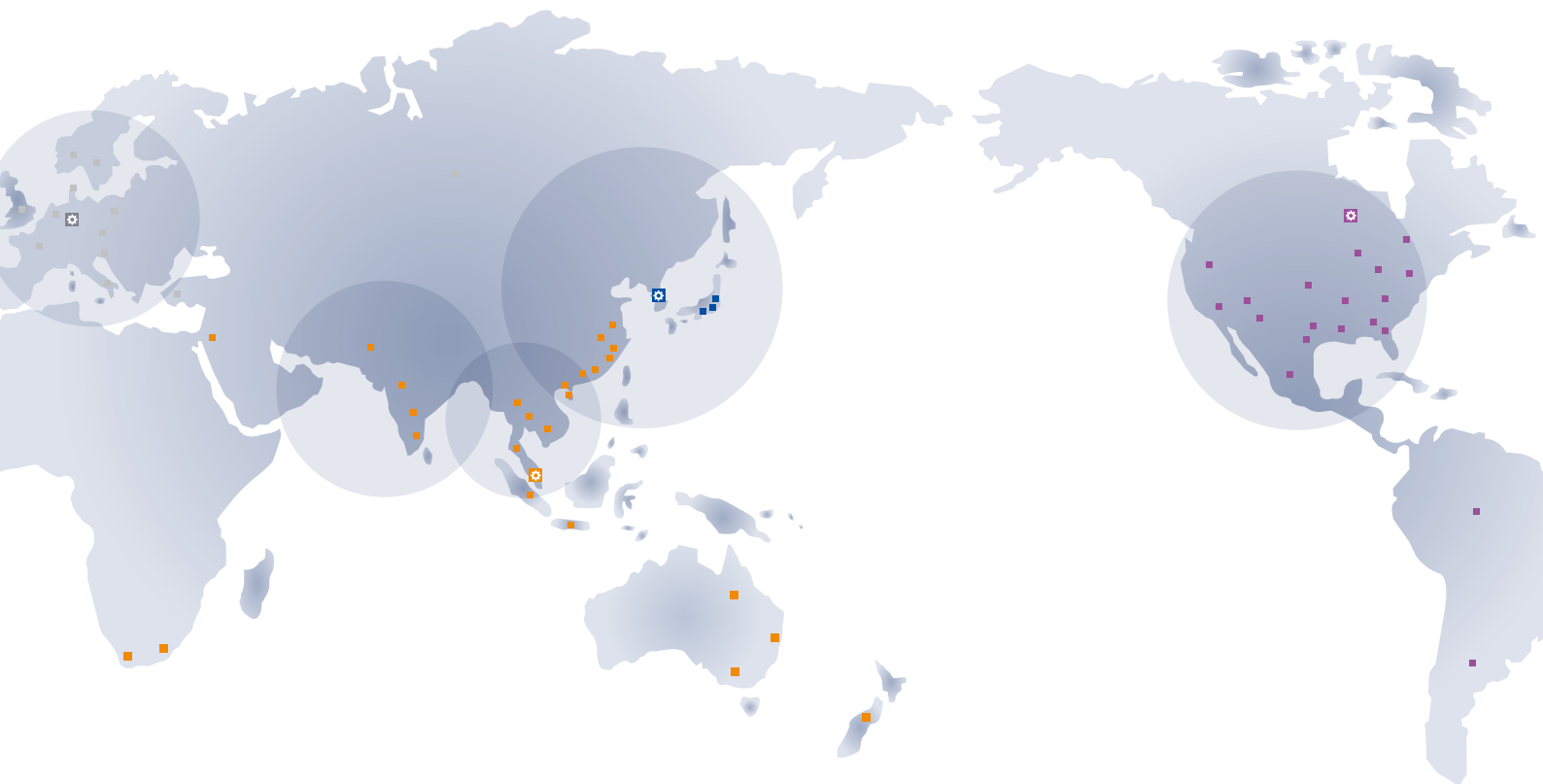

**HWACHEON**

Please call us for product inquiries.

[www.hwacheon.com](http://www.hwacheon.com)

The product design and specifications may change without prior notice.  
Read the operation manual carefully and thoroughly before operating the product,  
and always follow the safety instructions and warnings labels attached on the surfaces of the machines.

### HEAD OFFICE

#### HWACHEON MACHINE TOOL CO., LTD

976-1, JANGDEOK-DONG GWANGSAN-GU, GWANGJU, KOREA  
TEL: +82-62-951-5111 FAX: +82-62-951-0086

### SEOUL OFFICE

1022-7, BANGBAE-DONG, SEOCHO, SEOUL, KOREA  
TEL: +82-2-523-7766 FAX: +82-2-523-2867

### USA

#### HWACHEON MACHINERY AMERICA, INC.

50, LAKEVIEW PARKWAY VERNON HILLS, IL60061, USA  
TEL: +1-847-573-0100 FAX: +1-847-573-9900

### SINGAPORE

#### HWACHEON ASIA PACIFIC PTE. LTD.

21 BUKIT BATOK CRESCENT, #08-79 WCEGA TOWER SINGAPORE 658065  
TEL: +65-6515-4357 FAX: +65-6515-4358

### GERMANY

#### HWACHEON MACHINERY EUROPE GMBH

JOSEF-BAUMANN STR. 25, 44805, BOCHUM, GERMANY  
TEL: +49-2349-128160 FAX: +49-2349-128166